

Recording Drums in Modern Rhythm and Blues

By

Charese Harrison

A thesis presented to Middle Tennessee State University's Honors College in partial fulfillment of the requirements for graduation from the University Honors College

Summer 2023

Thesis Advisor: Professor John Merchant

Thesis Committee Chair: Associate Dean Philip Phillips

Recording Drums in Modern Rhythm and Blues

By

Charese Harrison

APPROVED:

John Merchant
Department of Recording Industry

Dr. Philip E. Phillips, Associate Dean
University Honors College

Abstract

As a drummer and an audio engineer, I have been interested in learning how knowledge in separate disciplines inform each other. For example, when recording an acoustic drum set, one must consider musical, technical, and architectural influences on the results. Learning how these interact highlights the importance of each area and benefits listeners who understand that music is a subjective art form as well as deliverable medium. Objectively, producers' technical choices during a recording like drum tuning and microphone selection, affect the resultant sounds, which may vary between styles. For this project, my primary focus was recording an acoustic drum set for modern Rhythm and Blues, a pop music genre that combines elements of jazz, gospel, and blues. For the audience to understand objective choices in music, it can be beneficial to compare sonic differences between specific techniques. To accomplish this, I conducted an experiment to showcase how instrument tuning, acoustic spaces, and microphone choices affect the sound of studio recordings. Using these recordings, I illustrate the impact subtle differences make in capturing sounds from an acoustic drum set in the context of a modern rhythm and blues arrangement. One of my goals for this project was to gain knowledge and experience and to become a better audio engineer, achieving sounds with knowledge of how to capture compelling sounds consistently.

Table of Contents

I.	History of Rhythm and Blues	1
II.	Rhythm and Blues Drummers	1
III.	Importance of Drums	2
IV.	Drummer	3
V.	The Acoustic Drum Kit	3
VI.	Drum Tuning	5
VII.	Aesthetics	6
VIII.	Acoustic Properties/Space	7
IX.	Microphone Selection and Characteristics	8
X.	Microphone Techniques	13
XI.	Recording Methodology	13
XII.	Recording Process	17
XIII.	Reflection	20
XIV.	Reference List	24

List of Figures

Figure 1. Acoustic Drum Kit	3
Figure 2. Drum Shells	4
Figure 3. Acoustically Treated Recording Studio	8
Figure 4. Dynamic Microphone Operating Principle	9
Figure 5. Electrostatic Induction Principle	10
Figure 6. Ribbon Microphone Operating Principle	11
Figure 7. Polar Pattern Graph	12
Figure 8. Live at Studio X	13
Figure 9. Telefunken Live from the Lab	14
Figure 10. Middle Tennessee State University's Studio D	14
Figure 11. Blumlein Pair Miking Technique	17

Brief History of R&B

The term Rhythm and Blues (R&B) is “a popular music genre combining jazz, gospel, and blues influences, a musical term for post-war musical chart listings which mainly encompassed the rich and varied folk music of the African Americans” (New World Encyclopedia, n.d.). Modern R&B instrumentation typically consists of vocals, keyboards, synthesizers, bass, and drums, often including a combination of acoustic and electric sounds. Rooted in American southern churches, R&B expanded in the 1940s in Northern urban cities like Detroit and Philadelphia. In the 1960s, artists like James Brown and Chuck Berry were categorized as rock performers but had strong influences on blues music as well, due to the widespread segregation that these artists experienced on racial biases: although white artists who drew from the same references were categorized as rock n roll, black artists were classified as R&B. Record labels like Motown and Stax Records produced hits by primarily black artists helped R&B become one of the most commercially successful genres (New World Encyclopedia, n.d.). Today, R&B has remained popular by evolving its artistic qualities and adopting qualities from hip hop, pop, and other modern styles.

R&B Drummers

Although there are many accomplished R&B musicians, modern R&B is an expansive genre that defies limitations in style and substance. Regardless, R&B drummers employ techniques that separate them from traditional rock or pop performers, like drum levels and intensity that may not match that of the lead vocalist, and performances often filled with creative choices. In context, R&B drummers commonly choose to play their part by being less flashy and providing simple but effective

propelling rhythmic elements for a song. In an article by Ahmir “Questlove” Thompson on his approach to drumming, he stated, “The idea was to sound disciplined, but with a total human feel,” (Thompson, n.d.). While some R&B songs include drum fills to add excitement and build tension before transitions, the combination of solid grooves and subtle fills are part of the artistic choices that make these songs conform to the artists’ and audience’s expectations.

Importance of Drums

Drums are a crucial component of the rhythm of many styles of music. Rhythm refers to a pattern of arranged notes in song, which can vary in length, loudness, and tonality, eliciting different moods, and composers often use drums and percussion to convey emotion. An example of this is “Stolen Moments Unplugged” by Alicia Keys, where the drums start off with a relaxed feeling, and as the drum part evolves towards the end of the song, its performance conveys a sense of excitement to the listener through more aggressive and varied hits.

In relation to the other players, the drummer’s performance choices help to define the tempo and rhythmic groove of a song. For pop musicians, playing “in the groove” or “pocket” means keeping a consistent rhythm going, interacting harmoniously with the rest of the band. Groove can affect how listeners respond to a song bodily from an elaborate dance to a simple head bob. Although groove can be interpreted subjectively by individuals, a well-crafted groove can be irresistible physically: when a song’s groove is compelling, the body automatically responds (Witek 573).

Drummer

The relationship between drummers and recording engineer can be special, notably when the engineer responds to creative energies of a drummer, and vice versa. This creative spark can often be the foundation for excellent recordings. When a producer chooses musicians for a session, they must consider their strengths and capabilities: for example, a jazz drummer might not be the best choice to perform on a pop song. Music production requires applied creativity and a skill for unique sounds: for this reason, there are few rules regarding the choices made during the recording process. Although average listeners are not listening for specifications of equipment or different plug-ins, these decisions can impact an emotional response. While recording gear plays a role in producing music, great recordings start with skilled performers.

The Acoustic Drum Kit

While drum instruments vary in size and quality, a conventional pop drum kit draws from a common collection of sources. The basic components of a five-piece acoustic drum set include a bass drum (also known as a “kick drum”), a snare drum, two tom toms, a floor tom, and a set of cymbals that often includes a hi-hat, crash, and ride. Figure one illustrates a typical five-piece kit with cymbals.



Figure 1. Five-Piece Acoustic Drum Set (Los Angeles Music Teachers, 2021)

Tonally, a drum instrument's outer shells and tuning determine the resonance and intonation of the source. Certain types of wood like maple tend to produce a rich tone with quieter transients, while birch shells typically produce a brighter sound with a faster attack (Toulson 26). Figure 2 illustrates a basic diagram of common types of drum shells in order from brightest to warmest sound. While there are no requirements for choices that drummers and engineers, these choices must align with the artist and producers' intended musical and sonic result.

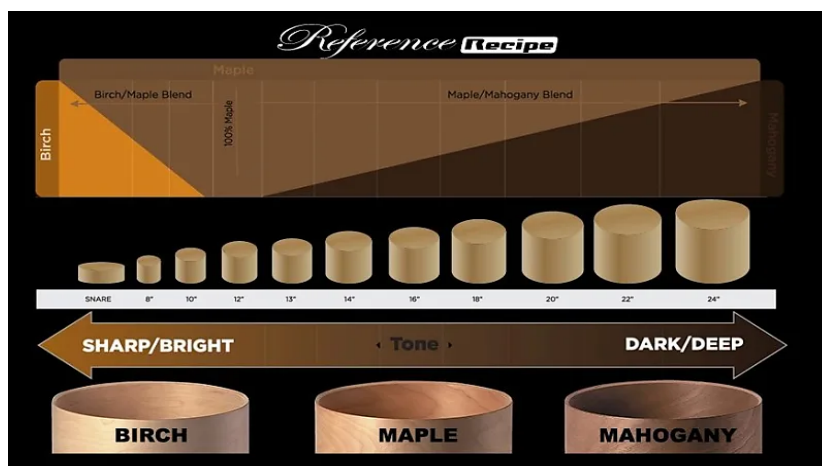

Figure 2. Drum Shells (Pearl, n.d.)

The visceral impact of an R&B song has a lot to do with the sound of the individual drum components and the notes played. Ghost notes, accents and flams, can elicit an emotional response from listeners. Adding complexity to otherwise basic dynamic contrasts demonstrate musical control. While it is important for a drummer to employ dynamic contrasts, the relative levels must remain consistent, establishing a balance between the drums and the rest of the band. If every musician played at the same volume throughout, it would be hard for the listener to differentiate parts of the song clearly. Dynamics provide an aural indication of changes in mood and intensity throughout the song's narrative.

Drum Tuning

One of the most overlooked aspects of recording drums is instrument tuning. While engineers have extensive processing options to shape individual sounds, these are no substitution for starting with a properly tuned acoustic source. Fortunately, drum tuning is a skill that is still employed by many drummers to maximize the sonic potential of a drum kit. Improper drum tuning can result in poor recording quality, inconsistent pitch across the kit, and may result in a mediocre performance from the drummer. “If your drumheads are too slack or too tight, the drum won’t resonate and project sound as well as it can. If a drumhead is tuned unevenly (e.g., tight on one side and loose on the other), the drumhead won’t vibrate smoothly and will choke the sound or introduce warbled artefacts to the sound” (Toulson 4). Achieving a consistent sound that blends harmoniously with the other instruments is always ideal when recording drums.

For drummers, it is difficult to play on an untuned kit. Unpleasant pitches and dissonant harmonies from each drum are qualities that even an average listener might notice. Tuning drums also allows the artist and engineer to experiment with different sounds and styles, producing unique sounds that fit the desired musical intention.

Tonality is the arrangement of different pitches and harmonies in relation to the musical tonic. While the tonality of a drum set differs from pitched instruments like guitar and piano, the ability to alter the intonation of different drums and cymbals is crucial to achieving compelling results. Each element of a drum kit has its tonal quality that can be tuned and adjusted to complement the song. For a drum to reproduce clear and full sounds, it must be tuned properly with the pitches kept within the appropriate tonal range of each instrument (Toulson 3).

The technical qualities of musical recordings are equally important to the creative choices involved when recording a song. Soundstage is related to the width and depth of an instrument's performance space, determining how elements of a song are perceived positionally within the recording. The spatial element of a drum kit relates to the perception of its left to right panorama and front to back depth. Although there is no specific way to alter a drum kit's image within a mix, there are common techniques engineers use for modern R&B production. One approach involves making the drum kit sound as it would during a live performance from the audience's perspective: "Items could be perceived as *separate*, which might be musically useful [...] This *separateness* reinforces the impress that they are "real" objects (which naturally cannot spatially coincide)" (Dean 19). Because the hi-hat is typically placed on the left of a right-handed drummer, it is common for the hi-hat to be positioned on the right side of mix, since this corresponds with the audience's perception. Considering most R&B kits do not consist of many drums, the drums spatialization should reflect this by having the elements of the kit positioned closer to the center image.

Aesthetic Decisions

For most modern recording projects, the producer oversees many of the song's aesthetics choices. Collaborating with an artist or group, the producer's role is to guide them through the recording process and help create a commercially viable final product that reflects the artist's vision. For some projects the producer may hire the musicians for the sessions and then guide their performances. "The concept of a *sound* in the sense of stylistic choice, and the ability to capture and mold it, have grown in importance as recording technology has become increasingly complex. Contemporary conceptions of

the role of the producer have been broadened through the example set by the work of a number of extraordinary figures” (Moorefield 38).

Ideally, recording engineers capture the artist’s and producer’s musical intent through the medium of recording technology. Technical choices like microphone placement and studio set are often decided by the recording engineer. Beyond the musical choices, recording engineers act as documentarian for a performance, with the goal of capturing the sound faithfully. If the performers’ goal of the song is to convey a relaxing mood, the engineer should choose the appropriate microphones and acoustical space that achieves the intended sonic results.

Space

Choosing an appropriate performance space for recording can help achieve high-quality results. Regardless of the genre, room acoustics should be a primary concern when recording acoustic sources. Acoustic isolation, room symmetry in control room design and monitor placement, absorption, reflection, and reverberation all impact a room’s acoustic response. Acoustic isolation keeps external noises at a minimum: purpose-built isolation rooms reduce sound leakage from other musical or environmental sources and are typically used for larger instruments such as drums. An isolation booth provides similar acoustic separation but is physically smaller, commonly used for vocals or single instruments. When recording a full band, it is common for both types of spaces to be used, depending on the overall size of the space and the number of instruments being recorded. For small scale experiments with only acoustic drums, an isolation room equipped with partitions (gobos) can create an acoustically controlled recording environment. Fibrous materials like rock wool are good for absorbing sound. “By using

the absorption materials in the studio, it can minimize the reflections while the recording is going, and it can also prevent the standing waves and flutter echoes” (Gupta 11).

Depending on the room size and quality of the space, there are many problems like phase issues that could arise, but fortunately, there are materials like acoustic panels and bass traps that help acoustically treat a space and manage these issues. Figure 3 illustrates a recording space that has been acoustically treated to manage problems that could arise.

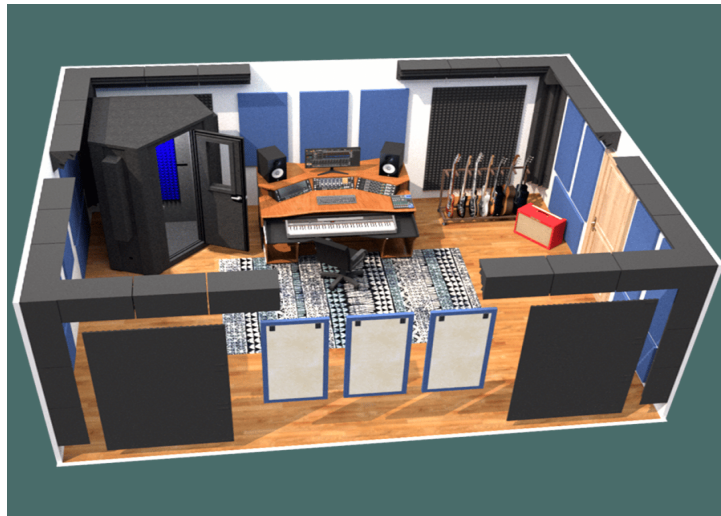

Figure 3. Acoustic Treatment (Whisper Room, 2022)

Waveforms are graphic representations of a sound wave moving through a medium. Acoustically, sound waves reflect off flat surface boundaries at an angle equal to their initial angle of incidence (Huber 93). Beyond simple reflections, sound may also diffract around or through physical barriers. When sound waves blend with reflections off nearby surfaces, these may create phase issues. Whenever waveforms of the same frequency and amplitude arrive at a microphone at similar times, it may result in the two signals arriving 180 degrees out of phase, canceling each other out.

Microphone Selection

Choosing the right microphone when capturing acoustic sources can be challenging. Microphones are transducers that convert acoustic energy into electrical

energy using different methods based on their principles. A microphone's tonal and timing characteristics impact the quality of the sound being recorded. A signal's sound quality depends on its placement, the source's acoustic environment and the quality of its design. Similarly, variables such as directionality, operating types, and diaphragm size also affect the recording quality (White 13). While there are no rules for microphone choice and placement, there are guidelines that can guide engineers' choices to achieve specific sounds.

There are three primary microphone types used in modern recording studios: dynamic, condenser, and ribbon. Dynamic microphones operate using electromagnetic induction. The diaphragm is attached to a conductive coil suspended in a magnetic field: when acoustic energy reaches the microphone, its diaphragm moves with the sound waves, inducing a current in the coil from magnetic flux as shown in Figure 4. Typically, dynamic microphones are more durable and able to capture higher sound pressure levels (SPL's) than condenser microphones. "As a result of their low output voltage and their ability to process high sound pressure levels without problems, moving-coil microphones are ideal for 'close combat' situations" (Pawera). Microphones placed closer to a sound source achieve a focused, dry sound.

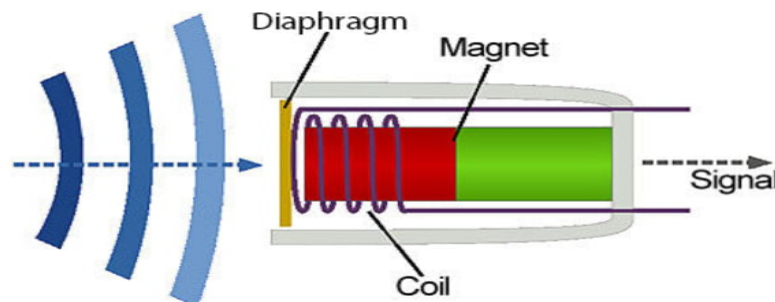

Figure 4. Dynamic Microphone Operating Principle (Thomann, 2023)

In contrast, condenser microphones operate on an electrostatic induction principle. The capsule of a condenser mic has two metal plates with opposite electrical

charges: one is a thin, movable diaphragm, and the other is a fixed back plate. Energy is stored between these plates with a device called a “capacitor,” which fluctuates when the microphones’, creating a voltage output as illustrated in Figure 5.

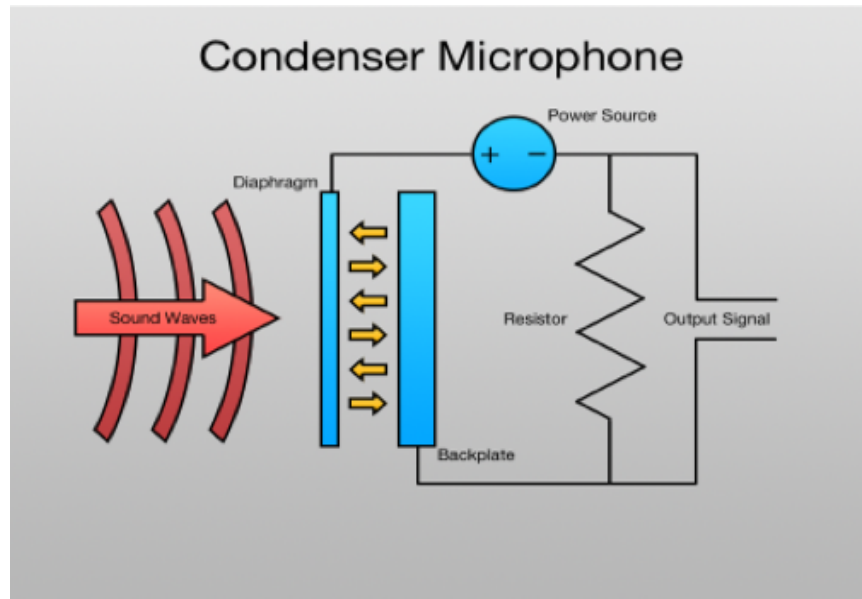

Figure 5. Electrostatic Induction Principle (Abney, 2017)

Finally, ribbon microphones also operate using electromagnetic induction. The difference between moving coil and ribbon dynamic microphones involves a thin aluminum ribbon diaphragm that moves when acoustic energy enters the microphone as shown in Figure 6. Although ribbon microphones are fragile and produce a lower output level, they are more sensitive to transients making them well suited to drum recording (White 31).

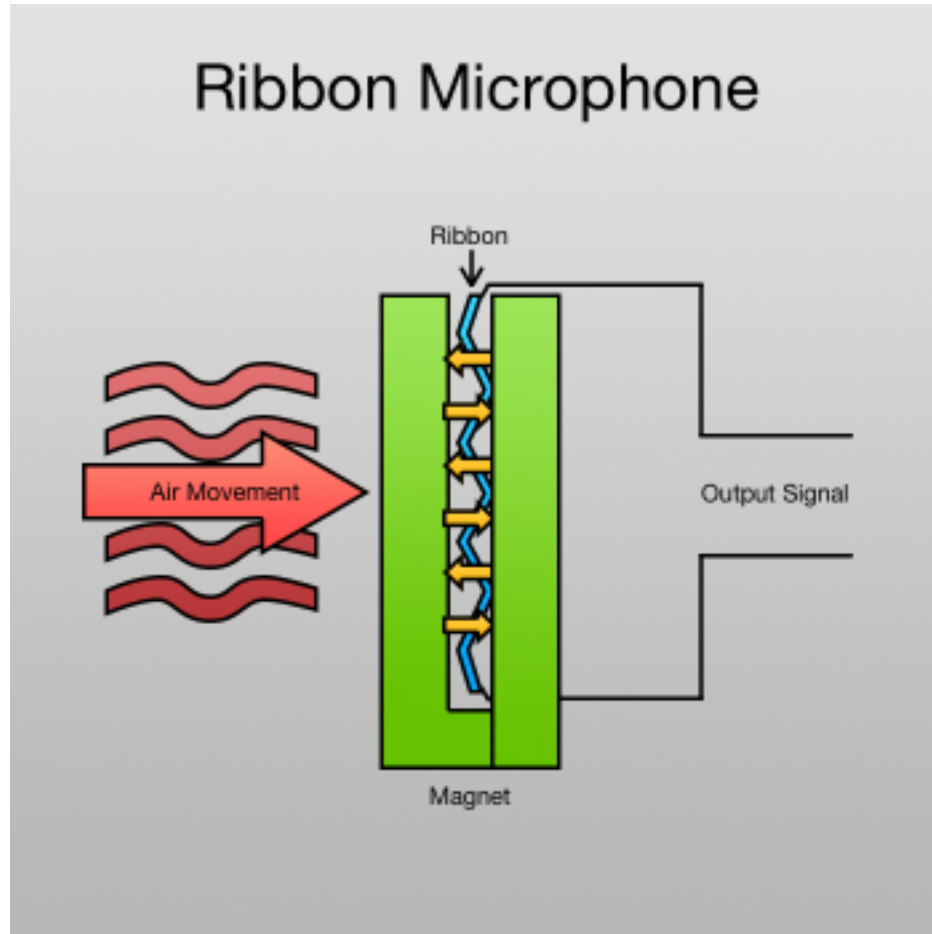

Figure 6. Ribbon Microphone Operating Principle (Abney, 2017)

Characteristics and Applications of Each Microphone

Microphones capture sound in different ways, depending on their design; understanding the characteristics of each microphone helps engineers achieve a desired sound. Beyond design, a microphone's directionality refers to how it picks up sounds arriving from all directions referred to as its polar pattern. The four most common polar patterns are omnidirectional, cardioid, hyper-cardioid, and bi-directional, also known as figure eight. Omnidirectional microphones are pressure-operated devices that respond directly to changes in air pressure and react equally to all sound pressure fluctuations at its surface. Cardioid and bi-directional microphones are pressure gradient microphones,

responding to the difference in pressure between the front and the rear of the capsule. A side effect of the design is proximity effect (White 17), which causes an increase in bass response when directional microphones are positioned within one meter of a sound source. To offset this effect, engineers can use a low-frequency roll-off filter and produce a more balanced spectral result (Huber 124). Cardioid microphones have the most sensitivity to sounds arriving directly in the front, making them an ideal choice for live or studio performances where off-axis sounds need to be kept to a minimum. A bidirectional microphone picks up sounds at equal levels from the front and rear of the capsule but not from the sides. This polar pattern is ideal for capturing a stereo image or ambience of a room because of its design which allows for a more focused stereo image by reducing unwanted noise arriving from outside of the desired image. The microphone polar pattern graph depicted in figure 7 illustrates how each type of microphone responds to sounds produced 360° around its capsule. These electrical and acoustical attributes are critical to understand when miking a drum kit.

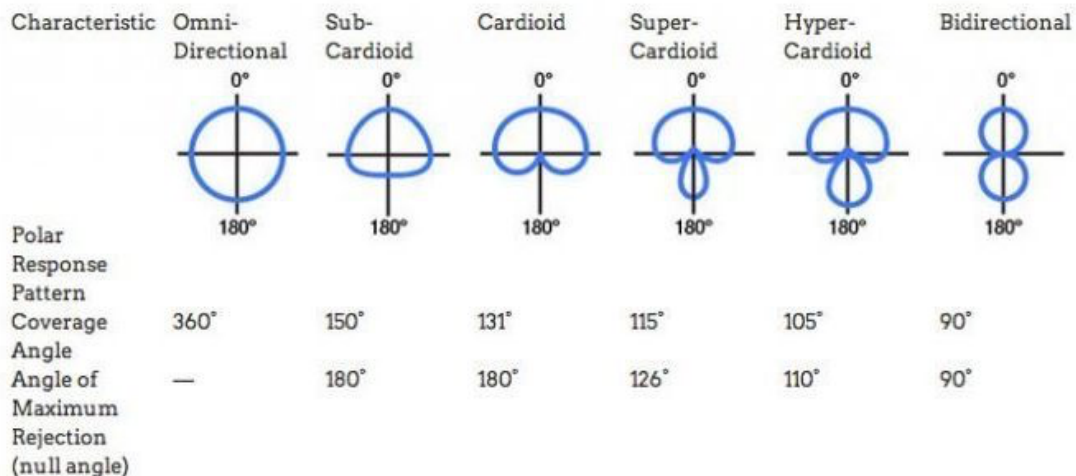

Figure 7. Polar Pattern Graph (Thomas, 2023)

Conventional Techniques

Selecting and positioning microphones are creative choices that play a crucial role in achieving optimal sound reproduction, balance, and clarity in a recording. There are typical miking techniques for capturing the sound of an acoustic drum kit. Different types of miking techniques include close miking, stereo miking, and ambient miking.

Recording Methodology Research

To study the impact of microphone choices and techniques for R&B recordings, I researched common techniques to determine how to achieve compelling results. My goal was to choose a well-known rhythm and blues song and recreate its drum sounds. To do so, I reviewed the technical and creative choices shown in live performances of “Naturally” by Allen Stone. The song was originally released in 2019 and recorded in an acoustically treated studio. Stone later recorded a live version at Telefunken Elektroakustik's facility in South Windsor, Connecticut. The test recordings for this thesis feature a combination of microphone techniques and choices inspired by Stone's recordings, though, final technical and creative choices were based solely on the engineer's and producer's desired sonic outcome. Figures 8 and 9 list the microphone choices displayed in the original recording, and figure 10 lists those used in my recreated instrumental.

KICK	UNKNOWN
SNARE	SHURE SM57
HI-HAT	AKG 451B
RACK TOM	AUDIX i5
FLOOR TOM	UNKNOWN
OVERHEAD SPACED AB	SMALL DIAPHRAGM CONDENSERS
SINGLE OVERHEAD	AEA A440 RIBBON
ROOMS	N/A

Figure 8. Live at Studio X (Stone, 2019)

KICK IN	TELEFUNKEN M82
KICK OUT	TELEFUNKEN M647
SNARE TOP	TELEFUNKEN M80
SNARE BOTTOM	TELEFUNKEN M81
RACK TOM	TELEFUNKEN M81
FLOOR TOM	TELEFUNKEN M81
OVERHEADS	TELEFUNKEN ELA M 260s
ROOMS	TELEFUNKEN M60

Figure 9. Telefunken Live from the Lab (Telefunken, 2017)

KICK OUT	NEUMANN TLM 49
KICK IN	SHURE BETA 52A
SNARE TOP	SHURE SM57
SECOND SNARE TOP	NEUMANN KM184
SNARE BOTTOM	AKG 451B
RACK TOMS	SENNHEISER MD 421
FLOOR TOM	AKG D112
HI-HAT	SHURE SM81
OVERHEAD HAT (BLUMLEIN)	AKG C414
OVERHEAD RIDE (BLUMLEIN)	AKG C414
ROOMS	EARTHWORKS QTC-30's

Figure 10. Middle Tennessee State University's Studio D

The final recording was recorded at Middle Tennessee State University's Main Street Studio D. To decide on the number of microphones to use for the final recording, my engineer Mitchell Breitmann and I considered whether we wanted a more open drum sound or if we wanted to capture a tight and focused direct sound for each element. Based on the reference recordings, fewer microphones would result in a more ambient recording and offer less control in the mixing process. We opted to use close-miking techniques on each drum plus distant miking techniques in the studio to capture both ambient room sounds and direct controlled sounds.

For consistency, all three test recordings used a Mapex acoustic drum set with Zildjian cymbals, though we used a Pearl Vision birch snare instead of a Mapex snare for the final recording. Each drum was tuned to the engineer's preference prior to recording. For example, the birch snare had a faster attack than that of a maple shell, and more closely matched the sound of the reference source. We also chose to tune the snare to a higher pitch, which brought out its bright attack, allowing the drum to be heard better in the mix. The rest of the drums' instruments were modified to reduce unwanted resonance.

Working in Studio D, the studio offered a wide range of acoustic possibilities. If we had recorded drums in the isolation room, the drums would sound clear with less ambient reverberation and more phase issues induced by reflections from the wall and sliding glass door. The large live recording space provided a more open sound with increased reverberation. Because we wanted to use microphones to capture the room's ambience, we chose the larger space that was more balanced spatially and tonally.

While the choice of microphones used for my sessions was essential, working with an experienced audio engineer had a greater impact on the results. For example, he chose to use a Neumann TLM 49 large diaphragm condenser microphone with a cardioid polar pattern. The design and characteristics of this microphone for the kick drum, which provided a full, warm, tone. To capture the kick's initial attack, he opted to use a Shure Beta 52A, designed to handle high sound pressure levels and low frequencies without producing an excess of low-midrange buildup, commonly called "muddy." Using two microphones on the kick drum captured the attack of the beater striking the drum along with the natural and rounded resonance of the instrument. Similarly, three microphones were used on the snare drum for different characteristics of the drum source, providing

options during the mixing process. The Shure SM57 and AKG 451B captured the sound of the rattling wires used on the resonant bottom, while an SM57 captured the crisp attack of the top batter head. While the SM57 was better for louder impacts because of its low sensitivity, the 451B is more sensitive and was suited to capture smaller details of an instrument such as quieter ghost notes. In addition, we used a Neumann KM184 to capture a unique perspective from the side of the snare, adding more of the natural tone of the source.

For toms, we used Sennheiser MD 421-II large diaphragm dynamic microphones known for their ability to handle high sound pressure levels without clipping. This microphone is ideally suited for rack toms because of their balanced spectral resonance and cardioid polar pattern, capturing the direct sound of the individual drum while rejecting off-axis sounds. While the 421 would have worked for the floor tom, we decided to use an AKG D112 to achieve a punchier sound with a clear low-end reproduction.

Recording cymbals can be challenging, and our goal was for this recording to include smooth sounding cymbals. AKG SM81s has a flat response curve that makes it great for reproducing accurate and natural sounds and can withstand loud sources without distorting. While close miking technique work for hi-hats to assure its presence in the mix, crash and ride cymbals are best recorded using overhead microphones. A pair of AKG C414s were arranged as a blumlein technique, utilizing two bidirectional microphones positioned next to each other at a 90° angle facing the source. Figure 11 illustrates the blumlein pair miking technique and how the two microphones should be positioned.



Figure 11. Blumlein Pair Miking Technique

Finally, we used a pair of Earthworks QTC 30s as the room microphones. QTC 30s are omnidirectional condenser microphones known for capturing the natural ambience of the performance space. With an extended 3Hz – 30kHz flat frequency response, this microphone is great for capturing the true tone without any unwanted boosts or cuts in certain frequency ranges.

Recording Process

When preparing for my large-scale test sessions, the engineer and I focused on recreating the exact drum sound from Stone’s song, “Naturally.” To accomplish this, I examined the microphones used in the video and compared their characteristics to those available for our sessions. However, considering differences in the studio and musical gear, we made a few adjustments, including the use of more microphones.

After critically listening to the original recording, Stone's drum sound was more natural and less processed than most modern R&B released. Stone's music is heavily influenced by a mix of 70s and 90s soul and New Jack Swing. The drums in the original studio recording are reminiscent of older R&B hits while also adding a bit of a modern feel to its performance and sound approach. I described the drums as "warm" with more midrange energy and low-pitched sounds with greater impact. For example, the snare is tight and crisp, but it does not sound as though it is tuned as tightly as possible, so I chose a snare with similar tuning. Over-tightening the resonant or batter head can result in a choked sound that was not my preference. Using high tension for the batter head while leaving tension in the resonant head achieved a more well-rounded warm sound that still cut through the mix.

The original kick drum recording was "punchy," a subjective term used to describe the low-end attack characteristic. To reproduce a "punchy" sound, I chose microphones that could reproduce low frequencies well and handle high sound pressure levels without distorting. The two microphones used for the recreated version achieved the desired sound by aiming the first microphone directly at the beater inside of the drum and the second at the center of the drum, approximately three to five inches away. The Neumann TLM 49 and Shure Beta 52A have a cardioid polar pattern, adding extra low frequency energy from the proximity effect. Blending both microphones resulted in a kick drum sound that was clear, warm, and punchy, like those in modern R&B recordings. Although the drummer doesn't utilize the toms too much during the recording, the rack toms and floor tom from the original recording could also be described as punchy and powerful. One challenge with recording toms deals with tuning:

if they are pitched too high, this could negatively affect the snare drum by causing a frequency overlap while too low could interfere with the kick drum tonally. During my sessions, the 10" rack tom was problematic because of unwanted overtones. To resolve this issue, we achieved a tone by loosening the bottom resonant head and making minor adjustments to the top batter head.

Recording cymbals using both close miking and overhead microphones was an interesting task. Using a small diaphragm condenser with a flat response curve helped capture the sound of the hi-hat faithfully and clearly. For the hi-hat, our goal was to achieve a crisp yet tonally subdued sound and the combination of microphone choice and placement along with the choice of cymbal achieved that. While it can be difficult to discern differences on first listen, focusing on specific tonal aspects to hear the subtle differences when comparing the rerecorded version to the original song. Capturing the crash and ride cymbals in addition to the overall drum kit using the blumlein pair took some adjusting, as it was critical to align the microphones to capture compelling balance of the cymbals with the rest of the kit.

We captured the room's ambience using omnidirectional condenser microphones, which added character to the mix and helped bring out the spaciousness of the tracking room. The acoustical space worked in our favor for the recording because of the thoughtful design of Studio D, which offered an ideal blend of reflection and absorption. We positioned the drums in the studio to reduce unwanted reflections during the recording. While I initially thought it would be a great idea to have the drum set facing the control room, the reflections from the sound bouncing off the window between the control room and live rooms made this option undesirable.

The final step of my full-scale experiment consisted of putting the arrangement together and creating a balance between the drums and the rest of the band. The mixing process was critical for achieving the authentic modern R&B feel; my goal was to achieve a smooth and soulful tonality with a strong backbeat, similar to the reference song. While the drums had already been balanced between elements, the final step dealt with adjusting levels, imaging, applying adding dynamic processing to balance the overall arrangement. As the purpose of this experiment was to recreate the original drums, I adjusted the levels of each instrument that complimented the vocalist. When listening to most pop songs, the vocalist is up front and positioned in the center of the mix with the instruments mixed in a way that does not distract from the lead element. However, because the primary focus of this experiment was the drums, I felt it was important to bring the drums out in the mix a bit more than the original to provide greater clarity for the listener.

In addition to using equalization to adjust frequency ranges, dynamic range compression is helpful for controlling loud peaks. Using the Teletronix LA-2A Compressor, I was able to reduce the loudest peaks in the audio signal and provided greater consistency throughout the performance. Doing so added a bit of distortion to the drums while also helping the drums sound natural without sounding overly compressed. Overall, the biggest advantage to using the Teletronix LA-2A was the added warmth and character of the drums from the unit's tube circuitry.

Reflection

My experiment demonstrated how the combination of microphone choice, placement technique, and an experienced musician contribute to creating a compelling

overall sound. While sonic quality is somewhat subjective, recreating drums for a well-known song helped me bridge the gap between subjective versus objective quantification. Regarding the acoustic drum kit, all technical and creative choices contributed to the resultant audio. After listening to the original song's live performance in Studio X and the Telefunken recording, it was clear that using an acoustically treated studio would be the better choice for capturing a controlled room character compared to the more reverberated sound in the Telefunken recording. Using a combination of microphone techniques from both performances helped to better capture the intended drum sound. The Telefunken recording did not use as much sound absorption as the one in Studio X, so the higher the number of hard surfaces a room has can directly affect the number of unwanted reflections in a recording. Although there are hard surfaces in Studio X, the combination of hard surfaces and absorption panels created a phasing sense of spaciousness.

For this experiment, I replaced the drums recorded in the Telefunken Lab with the recreated drums. Each of the three test recordings offers a sound unique to the engineer and producer that aligns with the creative goals of each production team. Regardless of task differences, proper microphone choice and placement are essential components of all good recordings. Many of the microphones used were designed to best capture drums, like those with cardioid polar patterns for rejecting audio bleed from adjacent sources. My goal when choosing microphones was to experiment with those that offered a unique tone and to explore how technical options affected the musical and creative results for specific applications.

I encountered many obstacles throughout the process of this experiment. The multitrack stems used in the final recording were taken directly from a live performance at the Telefunken Lab. After replacing the original drums with my rerecorded performance, we discovered that there was significant bleed or “spill” captured during the live recording. Although the original drums had been replaced with new drums, you could still hear the original drums bleeding through the other instruments. This bleed resulted from poor microphone placement and limited isolation from performers in a smaller space. Sometimes, spill across different microphones is inevitable, especially during live performances, and while there are ways to minimize this problem, these are better to address during the recording than after: dealing with spill in the mixing process is much more complicated, with limited control of each element separately. Even with significant processing, the bleed was a problem that we could not fully correct. If I were to redo this portion of the project, I would solve this problem by choosing a different song recorded in a better acoustic space or by separating the musicians during the recording. However, when the goal is to capture a full band recording live, it is essential for each member to be able to see and hear each other clearly, and musical considerations are often more compelling than technical ones.

My goal was to demonstrate the importance of microphone selection and placement in modern rhythm and blues recordings. By comparing the three recordings, listeners can consider the impact that technical and creative choices have on the overall results. Understanding this as a musician and audio engineer from my research has been enlightening; studying the differences between available options and hearing their impact

on the overall sound was extremely beneficial on my path towards becoming a professional audio engineer and musician.

Referenced Works

Abney, Mike. "Microphone Types." *AMP* 23 Apr. 2017. Retrieved July 24, 2023, from agilemusicproject.com/blog/?p=341.

Bartlett, Bruce, and Jenny Bartlett. *Practical Recording Techniques: The Step-by-Step Approach to Professional Audio Recording*. Seventh ed., Routledge, 2017, Retrieved 25 July 2023, from <https://www.book2look.com/embed/9781317445623>

Dean, Roger Thornton. *The Oxford Handbook of Computer Music*. Oxford University Press, 2011.

"Drum parts and what they are on a 5-piece set. Los Angeles Music Teachers." (2021, August 10). Retrieved March 3, 2023, from <https://www.losangelesmusicteachers.com/blog/drum-parts-and-what-they-are-on-a-5-piece-set>.

Fenske, D. (2017, July 31). *Take control of your recordings: understanding microphones*. Music Connection Magazine. Retrieved January 17, 2023, from <https://www.musicconnection.com/take-control-of-your-recordings/>.

Fox, A. (n.d.). *Microphone polarity & phase: how they affect mic signals*. My New Microphone. Retrieved April 1, 2023, from <https://mynewmicrophone.com/microphone-polarity-phase-how-they-affects-mic-signals/>.

Gallant, A. (2017). Home Recording 101: Microphone Basics. *Canadian Musician*, 39(5), 49–56. Retrieved December 2, 2022, from <https://web-p-ebscohost-com.ezproxy.mtsu.edu/ehost/detail/detail?vid=3&sid=8ce3f9af-4abb-48f9-ad33-e5047d3fc444%40redis&bdata=JnNpdGU9ZWhvc3QtbGl2ZSZzY29wZT1zaXRl#AN=125138207&db=asn>.

Gupta, Nandini. “AN ANALYSIS OF ACOUSTIC TREATMENT ON RECORDING STUDIO.” *International Research Journal of Engineering and Technology (IRJET)*, vol. 6, no. 10, 2019, Retrieved June 23, 2023, from <https://www.irjet.net/archives/V6/i10/IRJET-V6I10161.pdf>.

Huang, Z.-G., & Shiu, S.-J. (2015). Design and analysis of diaphragms in dynamic microphones. *Advances in Mechanical Engineering*, 7(7), 1–13. Retrieved January 7, 2023, from <https://doi.org/10.1177/1687814015595748>

Huber, D. M., & Runstein, R. E. *Modern Recording Techniques* (9th ed.). Routledge, 2019.

- Huff, C. (n.d.). *The importance of microphone frequency response*. Behind The Mixer. Retrieved November 20, 2022, from <https://www.behindthemixer.com/importance-microphone-frequency-response/>.
- Jack, D. (n.d.). *Why are drums important in a band?* Drum Sector. Retrieved February 1, 2023, from <https://drumsector.com/why-are-drums-important-in-a-band/>
- Johnson, D. H. (2006). *Signal-to-noise ratio*. Scholarpedia. Retrieved December 29, 2022, from http://www.scholarpedia.org/article/Signal-to-noise_ratio?iframe=true&width=100%25&height=100%25.
- Kendrick, P., Jackson, I. R., Fazenda, B. M., Cox, T. J., & Li, F. F. (2015). Microphone handling noise: Measurements of perceptual threshold and effects on audio quality. *PLOS ONE*, *10*(10). Retrieved February 9, 2023, from <https://doi.org/10.1371/journal.pone.0140256>
- MasterClass. (2021). *Home recording studio 101: How to record drums - 2021*. MasterClass. Retrieved January 21, 2022, from <https://www.masterclass.com/articles/home-recording-studio-101-how-to-record-drums#6-steps-for-recording-drums>.
- Moorefield, Virgil. *The Producer as Composer: Shaping the Sounds of Popular Music*. MIT Press, 2010.

Neumann. (n.d.). *How does frequency response relate to sound?* Neumann. Berlin.
Retrieved April 18, 2023, from <https://www.neumann.com/homestudio/en/how-does-frequency-response-relate-to-sound>.

N. W. E. (n.d.). *Rhythm and blues*. Rhythm and blues - New World Encyclopedia.
Retrieved February 1, 2023, from
https://www.newworldencyclopedia.org/entry/Rhythm_and_blues.

Pawera, Norbert. *Practical Recording 1: Microphones*. SMT, 2010.

“Questlove - Ahmir Thompson.” DRUMMERWORLD, Retrieved June 27, 2023, from
2023drummerworld.com/drummers/Ahmir_Thompson.html.

Schmitt, A., Ainlay, C., Cherney, E., Scheiner, E., Filipetti, F., Massenburg, G., Bolas, N., & Gibson, B. *Recording & Mixing Drums*. METAlliance/Bill Gibson, 2022.

Stone, Allen, director. *Allen Stone - “Naturally” (TELEFUNKEN Live from the Lab)*. *YouTube*, 2017, Retrieved July 25, 2023, from
<https://youtu.be/X0CGEIVJ9dc>.

Thomas, Christian. “How to Read a Polar Pattern Chart.” *SoundGuys*, 18 May 2023.
Retrieved July 25, 2023, from www.soundguys.com/how-to-read-a-polar-pattern-chart-16272/.

Toulson, Rob. *Drum Sound and Drum Tuning Bridging Science and Creativity*.
Routledge, 2021.

WhisperRoomTM. “The Difference between Sound Treatment and Soundproofing.” *WhisperRoom, Inc. TM*, 18 Nov. 2022. Retrieved July 24, 2023, from whisperroom.com/tips/the-difference-between-sound-treatment-and-soundproofing/.

White, P. Basic microphones. SMT, 2006.

Witek, Maria. “Groove Experience: Emotional and Physiological Responses to Groove-Based Music.” *JYX Publication Archive*, 2009. Retrieved July 23, 2023, from https://jyx.jyu.fi/bitstream/handle/123456789/20923/urn_nbn_fi_jyu-2009411334.pdf?sequence=1&isAllowed=y.